



SIGGRAPH 2003

SAN DIEGO



SIGGRAPH 2003
SAN DIEGO

Authoring of a Mixed Reality Furniture Assembly Instructor

Jürgen Zauner, Michael Haller, Alexander Brandl

FH Hagenberg (MTD) - Austria



Werner Hartmann

FAW - Austria



SIGGRAPH 2003
SAN DIEGO







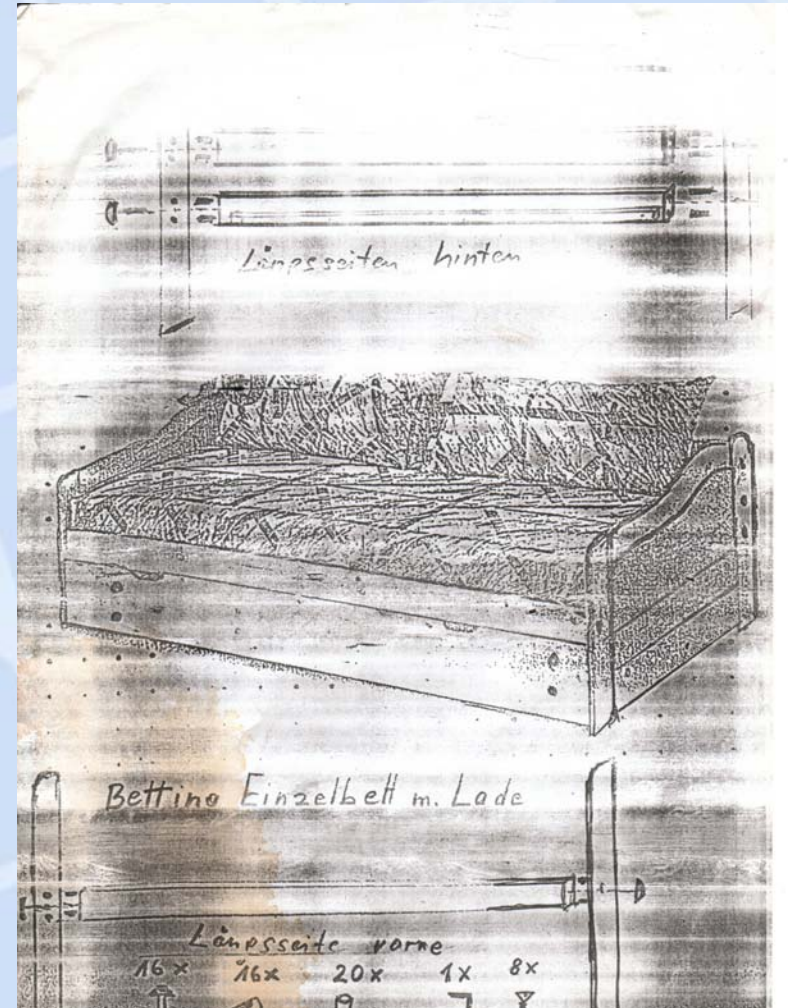
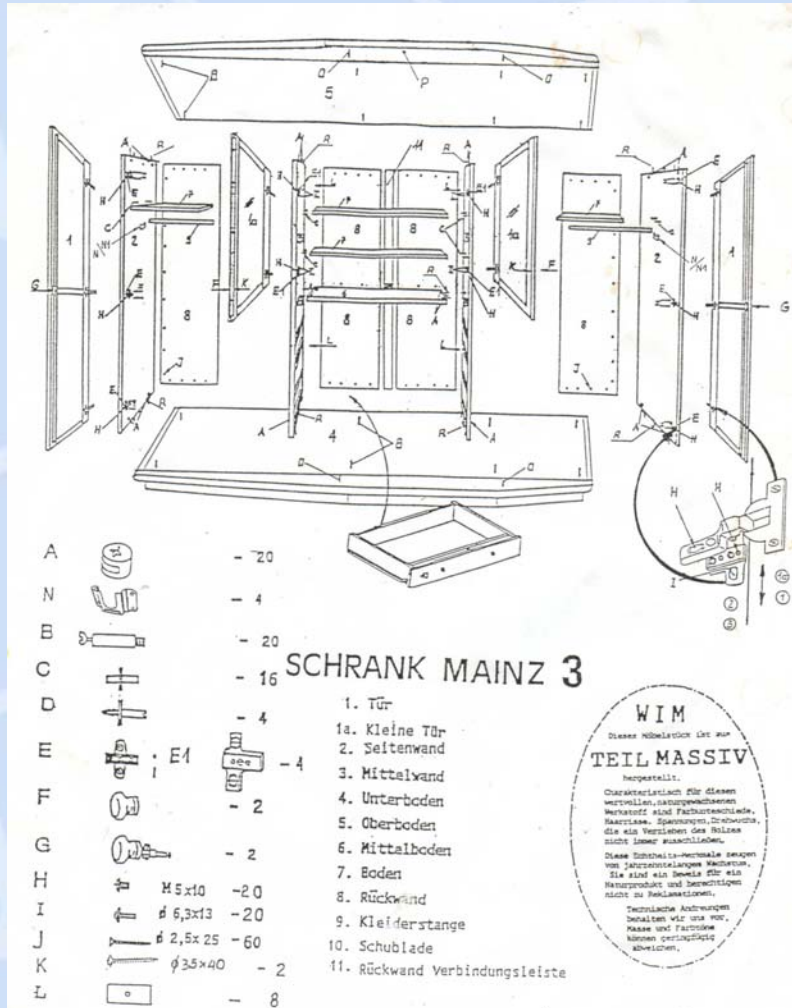

Motivation

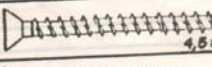
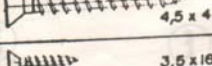
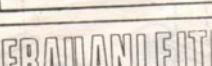
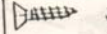
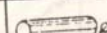
- Problem with conventional assembly instructions:
 - difficult to handle,
 - information overload, and
 - missing context.
- Reason:
 - need for interpretation, and
 - attention-switching.

Motivation II



Motivation III

NR	ZUBEHÖR	ST
A	 1/4 x 5/16" 4,5 x 50	01
B	 4,5 x 50	12
C	 4,5 x 40	06
D	 3,5 x 16	10
E	 30 x 13	20
F	 26 x 30 mm	26
G		01
H		01
I		04
J		01
K		02
L		01
M		02
N	 30 x 16	08

AUFBAUANLEITUNG

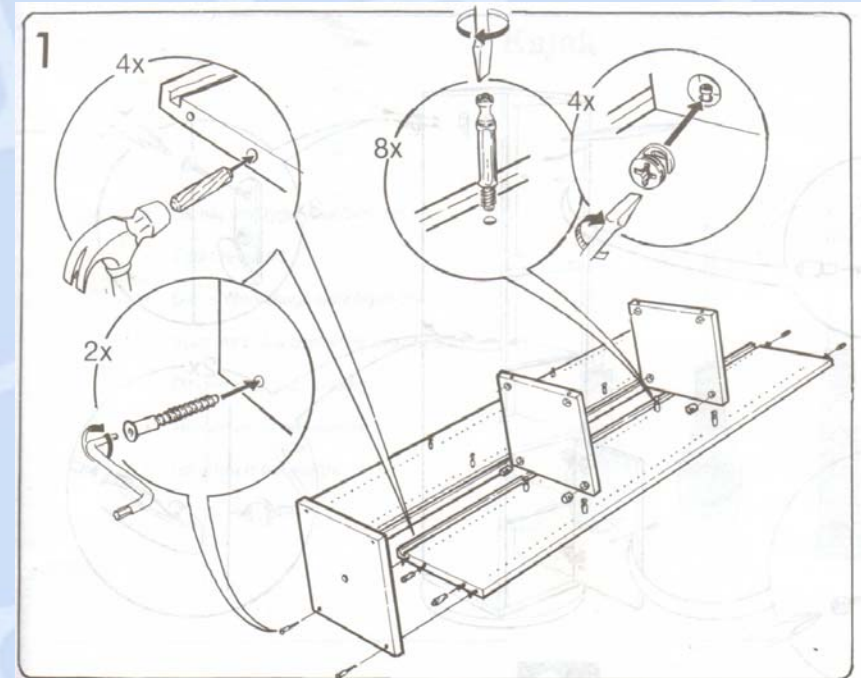
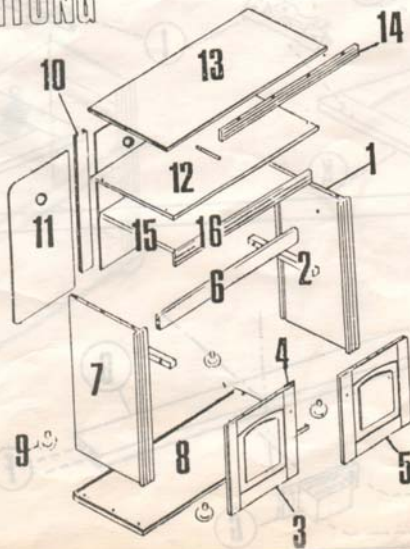



SIGGRAPH 2003
SAN DIEGO

Related Work

- Stavros Antifakos et. al.: Proactive Instructions for Furniture Assembly (in UbiComp 2002)
- Maneesh Agrawala et. al.: Designing Effective Step-By-Step Assembly Instructions (in Siggraph 2003)
- Thomas Pintaric (AEKI, Studierstube)

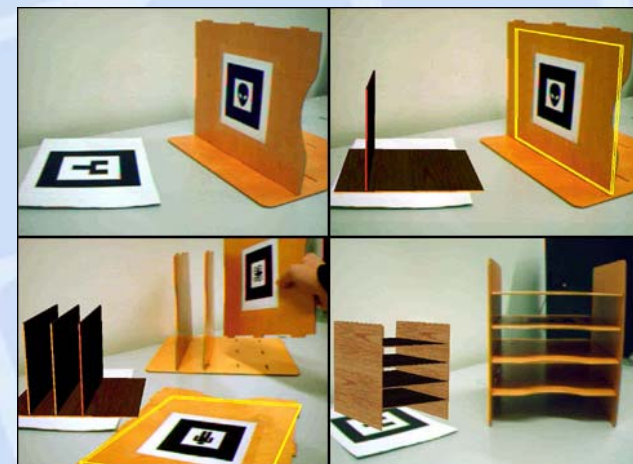
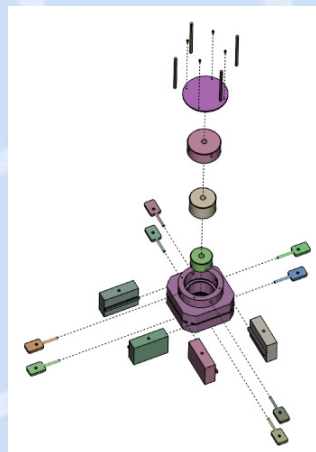



SIGGRAPH 2003
SAN DIEGO

Approach

- **Solution:**
 - context depending assembly instructions,
 - user interaction, and
 - clear assembly sequence.
- **Approach:**
 - Augmenting real furniture with assembly information (Mixed Reality technology),
 - Marker based interaction.



SIGGRAPH 2003
SAN DIEGO

Problem classification

- Furniture Assembly Instructor (Fai^{MR})
 - Expert:
 - Creating assembly instructions
 - Authoring mode
 - End user:
 - Assembling a structure
 - Application mode
- Mixed reality approach for both modes.

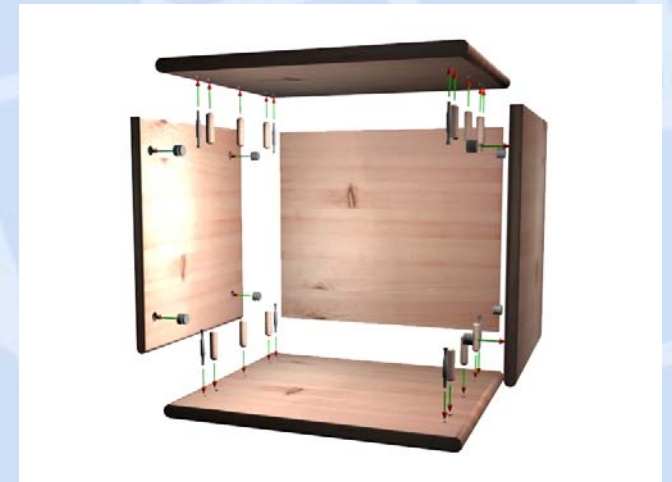



SIGGRAPH 2003
SAN DIEGO

Authoring Mode

- Placement of parts by markers.
 - relative offset-matrix,
 - using multiple markers to avoid marker occlusion.
- Undetectable small pieces:
 - temporary marker
- Export:
 - XML based assembly instructions

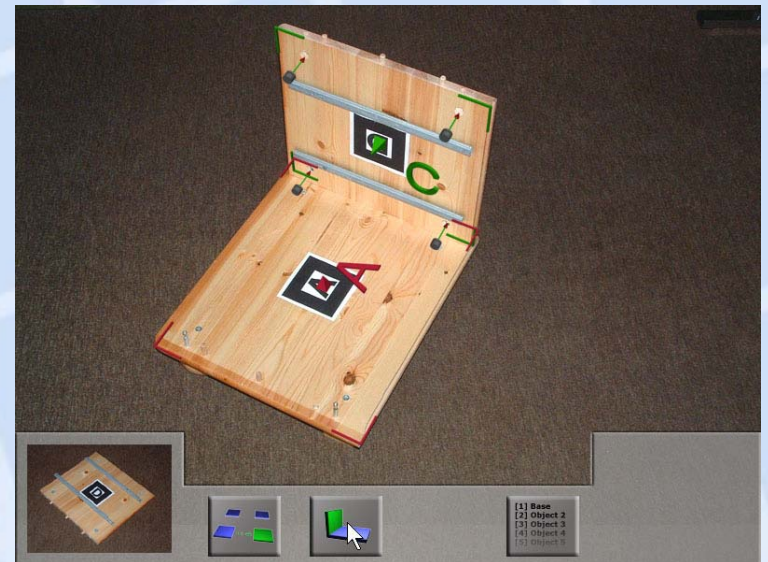



SIGGRAPH 2003
SAN DIEGO

Authoring Mode

- Placement of parts by markers.
 - relative offset-matrix,
 - using multiple markers to avoid marker occlusion.
- Undetectable small pieces:
 - temporary marker
- Export:
 - XML based assembly instructions



Authoring video



SIGGRAPH 2003
SAN DIEGO

Dataflow

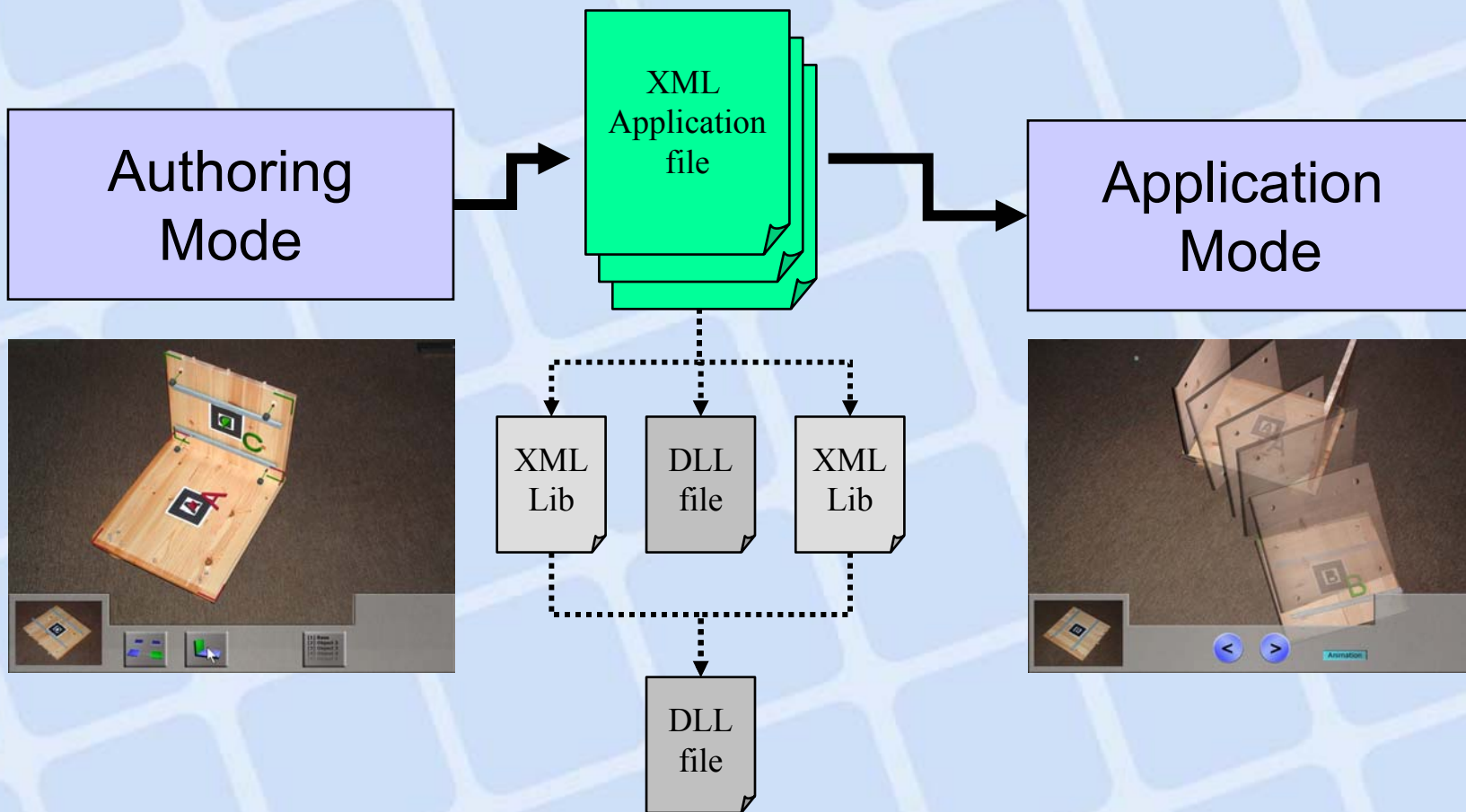

Application Mode

- Step-by-step assembly
 - Avoiding confusing multiple paths
 - Easy to handle data structure
- Indication of part placement by:
 - quaternion based animation (slerp-interpolation)

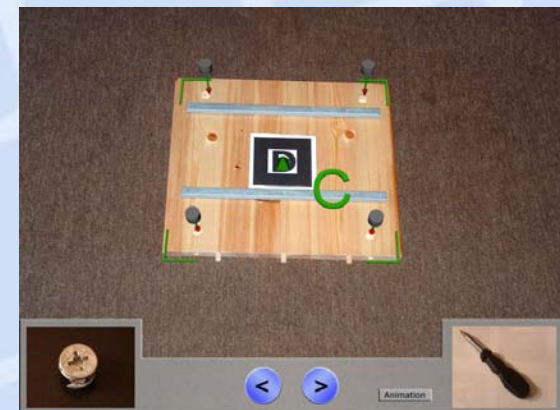
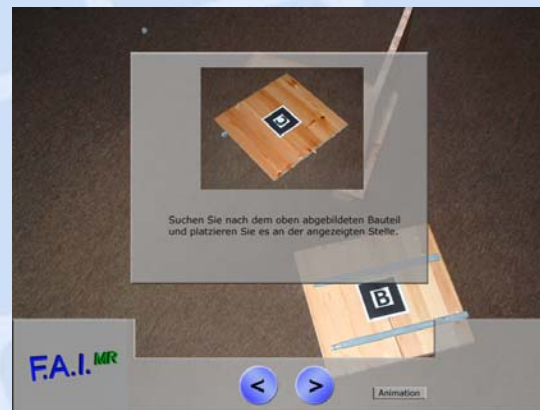

Application Mode II

- Step-by-step assembly
 - Avoiding confusing multiple paths
 - Easy to handle data structure
- Indication of part placement by:
 - quaternion based animation (slerp-interpolation)

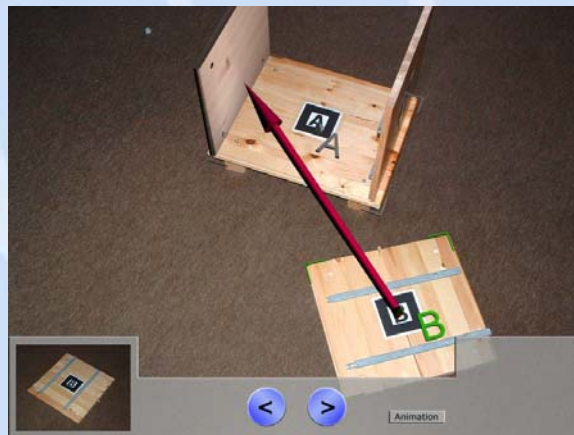

Application video



SIGGRAPH 2003
SAN DIEGO



SIGGRAPH 2003
SAN DIEGO

Used Technology

- Marker detection: ARToolkit
- Framework: AMIRE (Authoring of Mixed Reality)
 - Component based approach:
 - 3D-Models, GUI
 - Marker based “object” detection
 - OpenGL, OpenSceneGraph



SIGGRAPH 2003
SAN DIEGO

AMIRE framework

- EU funded project (IST-34024)
- Authoring tool for Mixed Reality applications
- Component based approach
- Authoring oriented design
- Plug-in-mechanism, e.g.
 - Marker detection
 - Image loading, geometry loading
 - ...



SIGGRAPH 2003
SAN DIEGO

Conclusion

- Intuitive proactive way
- Information is provided for the actual context
- The user's attention is focused on the assembly
- Authoring can be done by assembly experts instead of programmers
- Undetectable parts (small pieces) are problematic



SIGGRAPH 2003
SAN DIEGO

Future work

- Hierarchical structures
- Speech recognition (cf. command & control)
- Integration of other tracking technologies.
- Multiple markers for single parts
- Authoring of the marker-part-relation
- Applying the assembly instructor to other application fields

Questions



amire@fh-hagenberg.at

